

BIZERBA

■ ... closer to your business

Bizerba GSP series slicers are now certified to the new NSF ANSI 8 2010 standard.

Safety is our top-priority ...

... GSP H series – manual safety slicer ...

Bizerba is the first manufacturer to achieve this world-class standard!



GSP H

- Widest product carriage for increased capacity
- One piece anodized aluminum construction
- Fast and easy to clean, fewer seams, large radii
- Improved sealing against water and debris
- Largest and easiest to use remnant holder in the industry
- Unique design allows for the smallest end pieces, increased product yield
- Remote sharpener is dishwasher safe for improved safety and hygiene; spring-loaded dial insures correct and consistent sharpening
- The ergonomic design of the Bizerba GSP H series sets the standard for safety, yield, hygiene, durability, and lowest overall cost of ownership
- Low profile – reduces operator fatigue
- Largest thumb guard for maximum protection
- Zero blade exposure during the cleaning process
- Patented carriage interlock system
- One piece carriage with seamless thumb guard for highest hygiene standards
- Safety features: shut off in thickness knob, adjustable blade shut off and start at zero (safe-only)
- Improved liquid and debris diversion from all control surfaces
- Top quality gravity feed slicer with low-profile carriage for heavy products

Best blade in the industry

The unique design of our blade produces clean and consistent slices. The hardness results in a long lasting sharp edge. The life of the blade is dramatically longer than the competition.

Our standard blade is the hardest, thinnest, largest, straightest blade in the industry.

- 13" diameter, chromium coated hard alloy
- 60-62 Rockwell hardness at the edge





Project Name _____
 Model/s _____
 Number _____
 Quantity _____

BIZERBA

... closer to your business

1-phase AC current

- 120 V, specialised data available on request
- 60 Hz
- Frequency of nominal current 3.5 A
- Power consumption 0.360 kW

Blade diameter

- 13" (330 mm)

Blade speed

- 319 r.p.m.

Max. produce size

- Height: 4.96" (126 mm)
- Width: 11.6" (290 mm)
- Round: 8" (200 mm)
- Rectangular: 11.6 x 6.4" (290 x 160 mm)

Slice thickness

- 0-0.94" (0-24 mm), infinitely variable

Installation area

- (L x W) 20.94" x 18.82" (530 x 480 mm)

External dimensions (carriage inclined at 25°)

- (L x W x H) 28.54" x 23.07" x 23.46" (725 x 586 x 596 mm)

Operating area

- (L x W) 31.74" x 35.4" (806 x 899 mm)

Protection type

- IP 33

Weight of machine

- 95.1 lbs, 43 kg

Additional equipment

- Vegetable chute
- Product fences
- PW scale 120 V/60 Hz, 540 W



Carriage inclined at 25°

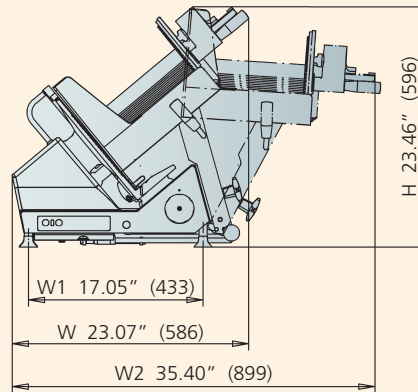
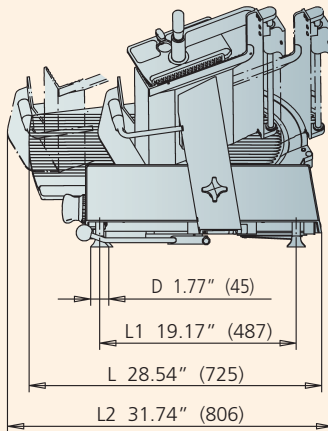

Warranty

The GSP H Safety Slicer carries a one-year, on-site parts and labor warranty against any flaws in materials and workmanship. This period begins with the date of purchase and, provided the unit is used properly in accordance with our instructions, is in full effect for one year from that date. Any work to be performed under this warranty must be performed between the hours of 8:00 a.m. and 4:30 p.m. local time, Monday to Friday. Bizerba will not pay over-time charges for work performed other than during normal business hours. Accessories have a 30-day replacement or repair warranty for the period beginning on the date of purchase. Damages incurred in transit or from installation error, accident, alteration or misuse are not covered. Transit damages should be reported to the carrier immediately. Bizerba shall not be liable for any consequential, compensatory, incidental, or special damages. All warranty work must be performed by a factory authorized Bizerba Representative.

Members of the Bizerba Group

Bizerba GmbH & Co. KG
 Wilhelm-Kraut-Straße 65
 72336 Balingen
 Germany
 Tel. +49 7433 12-0
 Fax +49 7433 12-2696
 marketing@bizerba.de
 www.bizerba.com

Bizerba USA Inc.
 31 Gordon Road
 Piscataway
 New Jersey 08854
 USA
 Tel. Office +1 732 565-6000
 Tel. Service +1 732 565-6001
 Fax +1 732 819-0429
 us.info@bizerba.com
 www.bizerbausa.com

Bizerba Canada Inc.
 2810 Argentinia Road #9
 Mississauga,
 Ontario L5N 8L2
 Canada
 Tel. +1 905 816-0498
 Fax +1 905 816-0497
 ca.info@bizerba.com
 www.bizerba.ca

Bizerba de México, S.A. de C.V.
 Av. Rio Mixcoac No. 157
 Colonia Florida
 01030 México, D.F.
 México
 Tel. +52 55 5663-1397
 Fax +52 55 5663-1296
 contacto@bizerba.com.mx
 www.bizerba.com.mx