



Fresh ideas in foodservice equipment



BKI's BLF-FC Electric Auto-Lift Fryer shown above

Agency Approvals:



Auto-Lift Fryers

Model: BLF, BLF-F, BLF-FC

Extra Large Volume Electric Automatic Lift Fryer with optional Computer and Filter

Easily implement and manage your fried food program with BKI's Auto-Lift Fryers. Load the food, set the fryer with the microprocessor control and within minutes, a basket full of juicy, delicious food automatically rises and is ready to be served. BKI's patented "Quick-Disconnect" filtration system helps ensure a simple and easy filter assembly removal process. Highest quality construction stands up to heavy use.

Exceptional pricing makes the BKI automatic lift fryer the profitable, value choice for any retail or catering business.

Standard Features:

- 18 lbs. (8.2 kg) Product, 75 lb (34 kg) Oil Capacity (6 Head Chicken)
- External Material (18 gauge, 304 Stainless Steel)
- 5" Casters for easy mobility
- Over-temperature shutdown
- Round well for easy cleaning

BKI North America
PO Box 80400
Simpsonville, SC 29680-0400 USA
Telephone: (864) 963-3471
Toll Free: (800) 927-6887

BKI Europe
Theale Technology Centre
Station Road • Theale
Reading • West Berkshire • RG7 4AA
Telephone: 0870 9904242 • Fax: 0870 9904243



Auto-Lift Fryers (BLF, BLF-F, BLF-FC)

Equipment Dimensions:

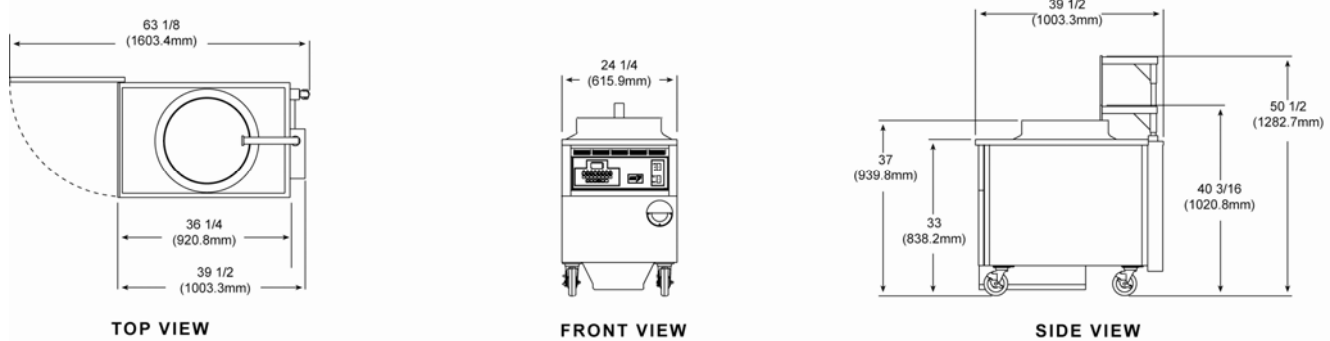

BLF-FC is depicted above but the dimensions shown apply to all models.

Mechanical Specifications:

Dimension	Uncrated	Crated
Height	33" (838.2 mm)	57" (1450.4 mm)
Width	24.25" (615.9 mm)	27" (687 mm)
Depth	39.5" (1003.3 mm)	42" (1068.7 mm)
Floor Space	6.7 sq. ft (.62 sq. m)	7.9 sq. ft (.73 sq. m)
Weight	325 lb. (147.4 kg)	340 lb. (154.2 kg)

Electrical Options:

Volts	Amps	Breaker	KW	Wires	Phase
208	47.3	60	17	3	3
220	37.5	50	14.3	3	3
240	41	50	17	3	3
220/380	21.7	30	14.3	4	3
230/400	22.8	30	15.6	4	3
240/415	23.7	30	17	4	3

Accessories (Optional)

	BLF	BLF-F	BLF-FC
FKF Remote Filter with small vat (231000)	✓		
FKF Remote Filter with large vat (231001)	✓		
FKF-H Remote Filter with Heater (231100)	✓		
Breading Table (420205) or (420206)	✓	✓	✓
Landing Table with Dump Tray (310600)	✓	✓	✓
Filter Vat Dolly (SB7650)		✓	
Filter Rinse Hose Assembly (SB2332)	✓	✓	✓
White drain brush (B0075)*	✓	✓	✓
L-Tipped brush (B0063)*	✓	✓	✓
White pot scrubber brush (B0049)*	✓	✓	✓
Bail handle basket (B0112)*	✓	✓	✓
Lid Cover and Hanger Assembly (AN16007300)	✓	✓	✓
13" insulating mitts (G0052)*	✓	✓	✓
cordset 7' (SB7655)			✓
Filter Paper (FI0007)**		✓	✓

* - Included with each model

** - 5 included with BLF-F and BLF-FC

Model Features

	BLF	BLF-F	BLF-FC
Microprocessor controlled for enhanced cooking capabilities			✓
"Quick-Disconnect" filter system to ensure user safety and proper filter alignment		✓	✓

BKI North America
 PO Box 80400
 Simpsonville, SC 29680-0400 USA
 Telephone: (864) 963-3471
 Toll Free: (800) 927-6887

BKI Europe
 Theale Technology Centre
 Station Road • Theale
 Reading • West Berkshire • RG7 4AA
 Telephone: 0870 9904242 • Fax: 0870 9904243

