

Project: \_\_\_\_\_ Location: \_\_\_\_\_ Item #: \_\_\_\_\_ Quantity: \_\_\_\_\_

### Standard Features

- Natural Gas or Propane
- Double wall kettle interior.
- Bottom kettle is hemispherical designed for superior heat circulation.
- Supported by a 1 5/8" diameter stainless steel pipe legs.
- Adjustable four hole feet for securing to the floor.
- Ability to manual tilt a full 90° for complete emptying.
- Power Switch, thermostat, pilot switch, low water light, vacuum/pressure gauge, safety relief valve and low water shut off.
- Fully Insulated.

### Optional Features

- Type 316 stainless steel liner for high acid cooking (ACGLT-60 only).
- 2" (50 mm) draw-off valve (ACTVT-2).
- 3" (76 mm) draw-off valve (ACTVT-3).
- 3" (76 mm) dairy valve (ACDDO-3T).
- Spring assist hinged stainless steel cover (ACCH-)
- Etched gallon markings (ACGM-)
- Etched litre markings (ACLM-).
- Correctional package

### Electrical Options

- 115 VAC, 1 Phase, 50/60 Hz.
- 208-240 VAC, 1 Phase, 50/60 Hz.

### Short Spec

Kettle shall be AccuTemp's ACGLT series self-generating, gas tilting kettle. A double wall kettle interior shall form a steam jacket around the lower 2/3 of the kettle. The jacket enclosure shall contain purified water which is factory sealed. The bottom of the kettle shall be of hemispherical design for superior heat circulation. The console shall be stainless steel clad and shall be supported on a heavy duty frame and the legs fitted with 4 hole adjustable feet for securing to the floor.

The kettle shall pivot on trunnion connected to the tilt mechanism and will permit the kettle to tilt forward a full 90° for complete emptying. The tilt mechanism is self locking for positive stop action. Construction shall be all welded #4 finish stainless steel. The kettle interior on models 20 through 40 gallon shall be standard stainless steel type 316 for high acid content cooking, the 60 gallon units shall be type 304 stainless steel. The controls are integrally mounted and shall include a power switch, thermostat, pilot light, low water light, vacuum/pressure gauge, safety relief valve, and low water shut off. The kettle shall operate in a temperature range of 165°F to 285°F (74°C to 140°C) at a maximum pressure of 50 psi (345 kPa).

### Other Approvals



**ACGLT-XX Model**  
with Optional Spring Assist  
Cover and faucet

### Accessories

- Triple basket assembly (ACTBA-).
- Perforated strainer for draw off (ACTPS-).
- Solid disc for draw off (ACTSS-).
- Contour measuring strip (ACCMS-).
- Strainer hook (ACSH-)
- Single pantry faucet with swing spout (ACSF-18).
- Double pantry faucet with swing spout (ACDF-18).
- Pan support (ACPC-1).
- Pour lip strainer (ACTKS-).
- Draw-off valve hose kit (ACDVHK-2).
- Calibrated thermostat dial, "F"
- Calibrated thermostat dial, "C"

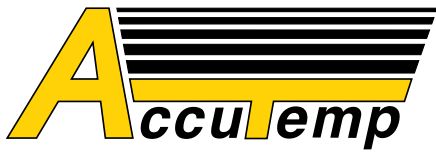

**GAS TILTING KETTLE**  
 20-100 GALLON CAPACITY—GAS FIRED,  
 MANUAL TILT, ELECTRONIC IGNITION

Gas Kettle Model "ACGLT" Specifications					
GAS SUPPLY					
Model #	BTU/HR.	KW/HR	SUPPLY PIPE PRESSURE (W.C.)		MIN CLEARANCE*
ACGLT-20	80,000	23.4	Natural 6"-14" (152-356mm)	Propane 11"-14" (279-356mm)	SIDES 0
ACGLT-30/40	100,000	29.3			BACK 4 [102]
ACGLT-60	120,000	35.2			

Dimensions																	
MODEL	SHIPPING WEIGHT	CAPACITY	UNITS	A	B	C	D	E	F	G	H	J	K	L	M	N	
ACGLT-20	700 [318 kgs]	20 gallons 76 litres	inches mm	20 508	48.13 1222	40.63 1032	19 483	40.13 1019	76.5 1943	16.5 419	24 610	11 279	22 559	40.5 1029	18.38 467	25.5 648	
ACGLT-30	900 lbs [408 kgs]	30 gallons 114 litres	inches mm	26 660	55.25 1403	43.63 1108	16.5 419	39 991	73.75 1873	15.5 394	22.25 565	7.5 191	21 538	38.13 968	17.88 454	28.5 724	
ACGLT-40	930 lbs [422 kgs]	40 gallons 152 litres	inches mm	26 660	55.25 1403	43.63 1108	16.5 419	43.25 1099	76 1930	15.5 394	22.25 565	7.5 191	23 584	42.5 1080	22.13 562	28.5 724	
ACGLT-60	1142 lbs [518 kgs]	60 gallons 227 litres	inches mm	30 762	59 1499	45.63 1159	17.88 454	43.88 1115	82 2083	19.5 495	22.25 565	5.5 140	23 584	45.5 1156	24.75 629	30.5 775	

**Notes:**

1. Supply gas through 3/4" pipe. A gas shut-off valve must be installed in supply piping convenient and adjacent to appliance.
2. Unless otherwise specified, Field Wire Electrical Connection to be 120V, 60Hz single phase with grounding wire. Unit supplied with 6' cord and 3-prong plug. Max AMPS: 4.0
3. Hot and Cold Water: 3/8" OD tubing to faucet (OPTIONAL).

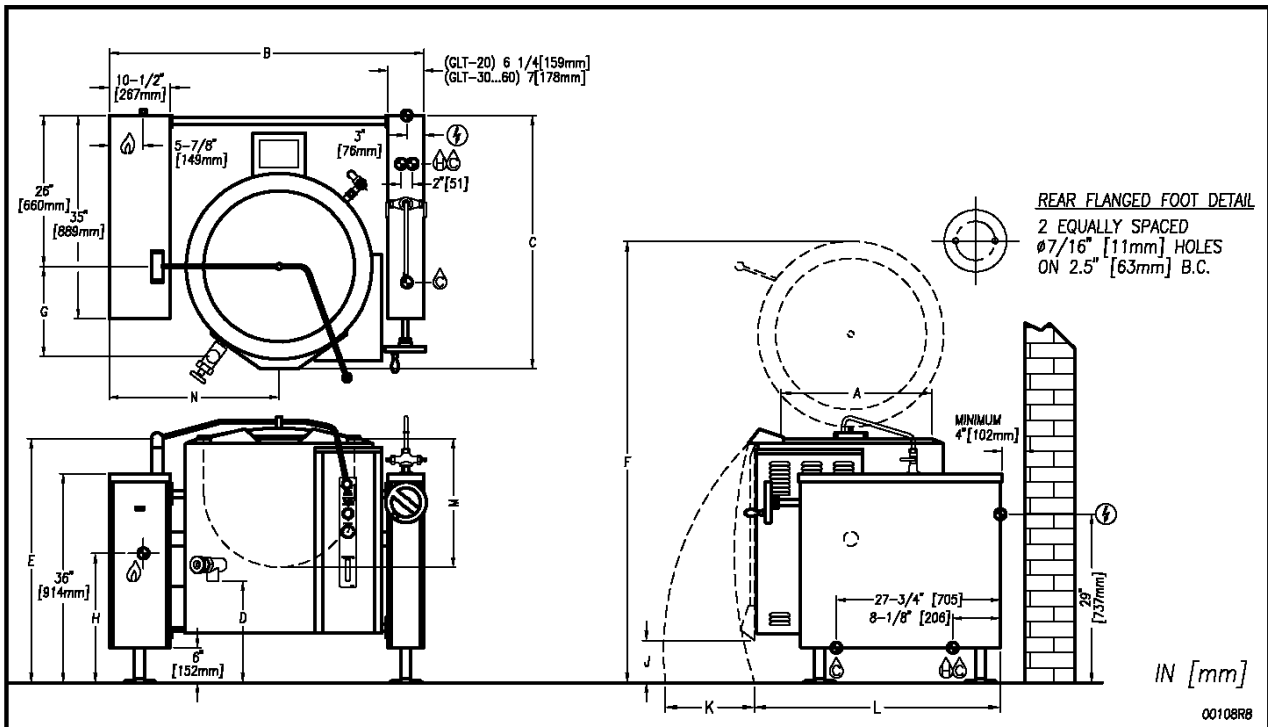

MM6226-1105