

MOFFAT E85-A-12-HLD

Proofer and Holding Cabinet

-  Full view door
-  Dual proof/holding functions
-  Variable heat control
-  Variable humidity control
-  Stainless steel outer
-  Stainless steel inner
-  Low velocity fan
-  Casters as standard
-  110V plug in connection
-  Door removes for cleaning
-  Auto water fill (hook-up optional)



E85-A-12-HLD



Order Toll Free 1800 551 8795

E85-A-12-HLD

Unit shall be a Moffat electrically heated proofer and holding cabinet E.T. L listed (UL Std 197 NSF - 4). The proofer and holding cabinet shall have a stainless steel interior and stainless steel top and sides. Proofer cabinet shall be fully insulated with a single pane removable glass door with capacity for up to 24 half size sheet pans or 12 full size sheet pans. A single speed fan shall gently and evenly circulate air around the proofer cabinet. Cabinet temperature shall be controlled by a thermostat and humidity via a humidity sensor and control. A thermometer shall indicate the cabinet temperature. A single element shall heat the cabinet with an additional element heating water in the water tank. Proofer and holding cabinet shall be mounted on casters, fixed at the rear, brake and swivel at the front. Proofer and holding cabinet shall operate independently or in combination with Moffat's Turbofan model E35. Proofer and holding cabinet shall be fitted with a NEMA 5-15P cordset.

MOFFAT® E85-A-12-HLD

Proofer and Holding Cabinet

CONSTRUCTION

- 12 pan capacity
- Stainless steel front and sides
- Removable full view door
- Strong and stylish handle
- Stainless steel racking system
- Accepts half or full size pans
- Fully insulated
- Porcelain control panel

CONTROLS

- Off/proof/hold switch
- Mechanical thermostat
- Variable heat 32°F to 175°F
- Variable humidity
- Cabinet temperature thermometer

CLEANING AND SERVICING

- Easy clean surfaces
- Removable racking system
- Removable water tank

SPECIFICATIONS

Electrical Requirements
110V, 60Hz, 1P+N+E, 1.65kW, 14.5A
NEMA 5-15P cordset fitted



Water
3/4" thread
80psi max inlet pressure
20psi min inlet pressure

External Dimensions

Width 34⁵/₈" (880mm)
Height 45¹/₈" (1145mm)
Depth 34⁵/₈" (880mm)

Internal Dimensions

Width 18" (460mm)
Height 37¹/₄" (945mm)
Depth 26" (660mm)

Nett Weight

265lbs (120kg)

Packing Data

399lbs (181kg)
44.5ft³ (1.26m³)
Width 38¹/₈" (970mm)
Height 51¹/₈" (1300mm)
Depth 39³/₈" (1001mm)

Clearances

Left side -
Right side 1" (25mm)
Rear -
Top -

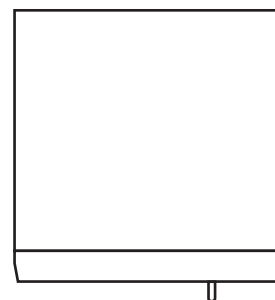
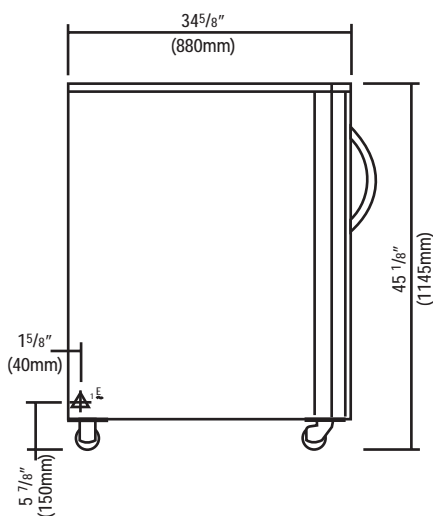
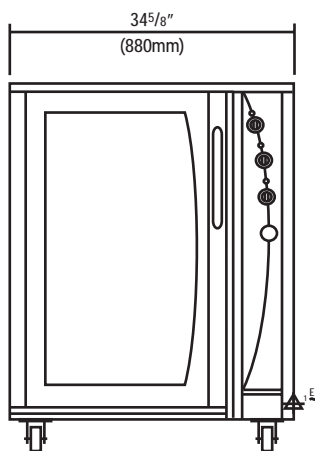

Door swing 25¹/₂" (650mm)



ISO 9001

All Turbofan products are designed and manufactured by Moffat Ltd using the internationally recognised ISO 9001 quality management system, covering design, manufacture and final inspection, ensuring consistent high quality at all times.

MOFFAT®

www.moffat.com

U.S.A

Moffat Inc
3765 Champion Boulevard
Winston-Salem
North Carolina 27105
Call Free 1800 551 8795
Ph 336-661 0257
Fax 336-661 9546
Email sales@moffat.com
www.moffat.com

Canada

Serve Canada
22 Ashwarren Road
Downview
Ontario, M3J 1Z5
Ph 416-631 0601
Fax 416-631 0315
Email info@servecanada.com

Australia

Moffat Pty Limited
740 Springvale Rd
Mulgrave
Victoria 3170
Australia
Ph 03-9518 3888
Fax 03-9518 3833
Email vsales@moffat.com.au
www.moffat.com.au

New Zealand

Moffat Limited
16 Osborne St
PO Box 10-001
Christchurch
New Zealand
Ph 03-389 1007
Fax 03-389 1276
Email sales@moffat.co.nz
www.moffat.co.nz

United Kingdom

Blue Seal Limited
Units 6-7 Mount St
Business Park
Birmingham B7 5QU
England
Ph 0121-327 5575
Fax 0121-327 9711
Email sales@blue-seal.co.uk
www.blue-seal.co.uk