

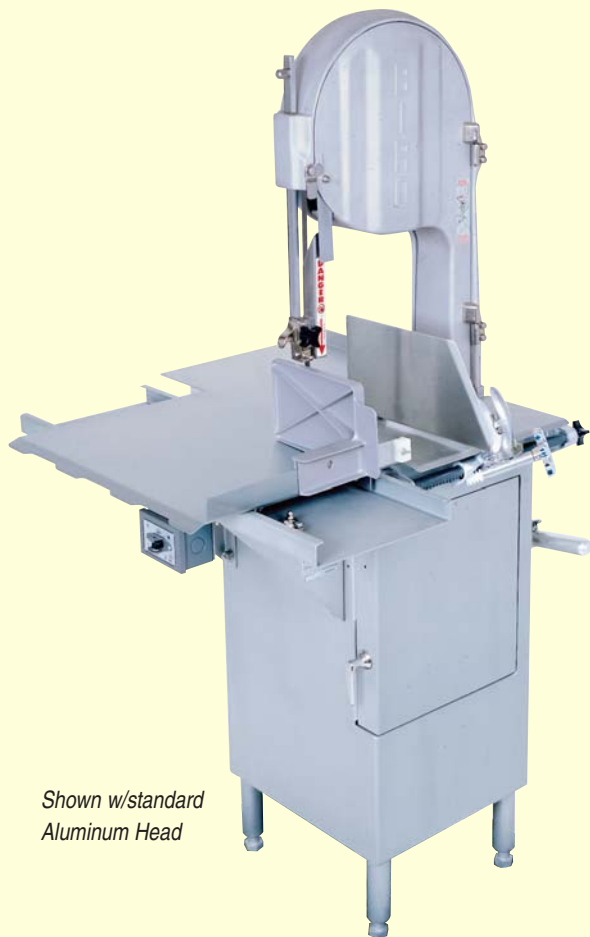

**Known for
Reliability
Since 1921**

The BIRO Model 22SS Meat Saw, 12" (304.8mm) diameter Blade Wheels, 91" (2311.4mm) Saw band is a smaller saw that's ideal for small meat shops, grocery service meat counters, and fish shops. It's 1-1/2HP motor has the power and size to meet your custom meat and fish cutting needs. The unitized welded stainless steel base and cast aluminum head (optional stainless head) resist corrosion and ensure long equipment life. The upper wheel assembly and lower wheel drive assembly utilize tapered roller bearings for smooth operation and low long term maintenance. It's separated, enclosed motor compartment helps protect the motor against moisture and corrosion. The optional stainless steel head assembly and optional watertight magnetic switch assembly turn the 22SS into a perfect production saw for meat, poultry and fish cutting operations. Our 22SS incorporates the superior design and engineering you've come to expect from BIRO, which means you'll get years of use, low maintenance, and lower overall cost of ownership.



*Shown w/standard
Aluminum Head*



*Optional extra cost
Stainless Steel Head*

22SS

SPECIFICATIONS

Model: Model 22SS 12" (303mm) Power Meat Saw Series

Motors:

HP	KW	TYPE	VOLTS	AMPS	CYCLE	PH	STATUS
1-1/2	1.1	HH	115/208-230	17.8/9.6	60	1	STD
1-1/2	1.1	HH	208-220/440	4.6-4.2/2.1	60	3	STD
1-1/2	1.1	HH	110/220	13.6/6.8	50	1	EC
1-1/2	1.1	TE	115/208-230	17.4/9.6-8.7	60	1	EC
1-1/2	1.1	TE	208-220/440	4.4-4.0/2.0	60	3	EC
1-1/2	1.1	HH	220/380-415	4.7/2.7-2.5	50	3	STD
1-1/2	1.1	TE	220/380-415	4.1/2.4-2.2	50	3	EC
2	1.5	OP	230/460	5.6/2.8	60	3	EC
2	1.5	OP	220/380-415	5.8/3.4-3.2	50	3	EC

TE=Totally Enclosed OP=Open HH=High Humidity
STD=Standard EC=Extra Cost

Construction: Stainless steel base, Aluminum head standard; Stainless Steel head structure (optional – extra cost)

Standard Features: Two saw blades • Operation and safety manual • Safety wall poster • End cut safety pusher plate.

Switch: Toggle, standard, 2HP rated.

Head and Door: Aluminum, (optional stainless steel), entire assembly removable.

Base Structure: Stainless steel.

Blade Standard: Hard tooth, four teeth per inch, 5/8" (16mm) wide, .020 (.051mm) thick, 91" (2311mm) long (two supplied with each saw).

Blade Speed: 3000 feet (914m) per minute approximate.

Blade Guide: Upper and lower blade backup removable guide assemblies, with long life carbide backup inserts.

Blade Wheels: 12" (30.4cm) cast iron, chrome nickel plating, upper wheel assembly lifts out.

Bearings: Heavy duty tapered roller bearings used in upper wheel and lower bearing housings.

Catch Pan: Poly, extra deep, rounded corners, bone dust pan sealed off from other parts of base, accessible through base hinged door.

Cleaning Unit: Stainless steel body, long-life carbide guides, steel saw cleaners, removable as a unit for easy cleaning.

Drive System: Non slip silent v-belt, tension adjustable.

Legs: Four (4) stainless steel leg bolt levelers.

Meat Carriage: Stainless steel with nylon guides and steel bearings, removable thumb guard.

Meat Gauge Plate: Stainless steel faced, adjustable from 1/16" (1.59mm) to 6-1/2" (165mm) locks in position, can be thrown out of gear, entire assembly removable for cleaning.

Motor Compartment: Sealed off from meat contact areas, easily accessible through removable panel door.

Platter: All stainless steel, held in place with two push pull hold down stainless steel rods.

Safety End Cut Pusher Plate: Standard, removable.

Options (EC): Power cord and plug • Totally enclosed motor • Watertight magnetic switch with thermal overload and under voltage protection • Stainless steel head • General purpose manual push button switch, 2HP motor • Stationary front table, see drawing at right.

Certification: U.L., N.S.F., U.S.D.A., C.S.A., C.F.I.A.

Weight: Uncrated: 308 lbs. (140 kg) approximate; Crated: 336 lbs. (152 kg) approximate: Stainless Steel Head – add 20 lbs. (9 kg).

Dimensions Crated: L=32" (81.3 cm), W=40" (101.6 cm), H=38-1/2" (97.8 cm), cube 28.5.

Model 22SS
w/Standard Aluminum
Head Structure

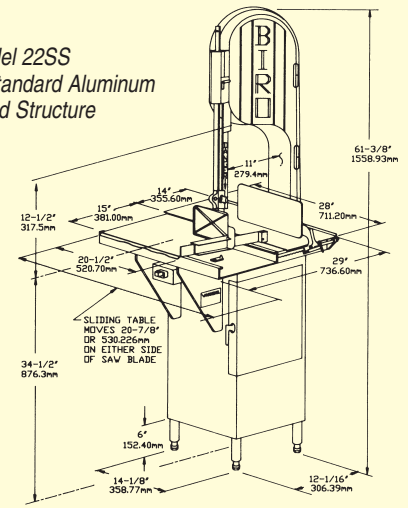

Model 22SS w/Optional
Stainless Steel Head
and Door Structure

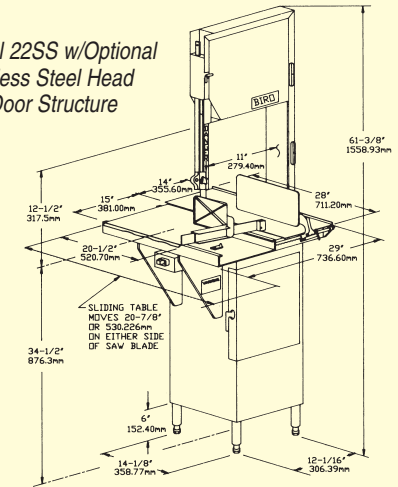

Model 22SS Trim Saw
available w/optional
Stainless Steel Head
and Door Structure and
Front Stationary Table

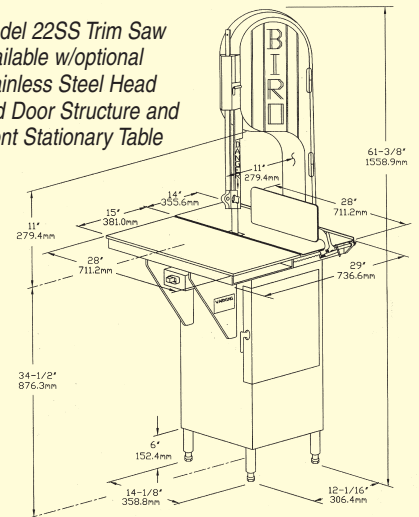

BIRO MANUFACTURING COMPANY
1114 WEST MAIN STREET
MARBLEHEAD, OH 43440-2099 U.S.A.
Phone: (419) 798-4451
Fax: (419) 798-9106
<http://www.birosaw.com>
sales@birosaw.com

ITEM NO.: LIT-22-008

FORM NO.: Md 22-008-4-12-55 ENG MARK

ALL SPECIFICATIONS CONTAINED HEREIN ARE SUBJECT TO CHANGE WITHOUT NOTIFICATION.

Service is available from locations worldwide